

Cost-Effective Solutions

"BTN" Series offers cost-effective solutions for light industries.

Light-Weight Housing

BTN with ABS plastic and IP54 protected housing is designed for indoor applications.

Relay Contacts

On board provided relay contacts allow to manage other equipment such as siren, flasher. Also, it can be linked to firefighting panels.

Sensitive Sensors

High quality Catalytic, Electrochemical and Semi-Conductor sensors employed BTN Series detectors show excellent results in LEL, ppm and VOL ranges.

Optional Universal Communication Protocols

Thanks to Optional Modbus RS485 RTU Module, BTN can be managed as addressable detector.

Fall-Safe Technology Alarming

Alarm 1 and Alarm 2 relays are easy to set to default LEL, ppm, VOL levels. The fault relay output properly indicates fault status.

Applications

- Safe-area applications
- Laboratories
- Food and Medicine Facilities
- Kitchens

Optional Modules

BTN-RS: Modbus RS485 RTU interface module

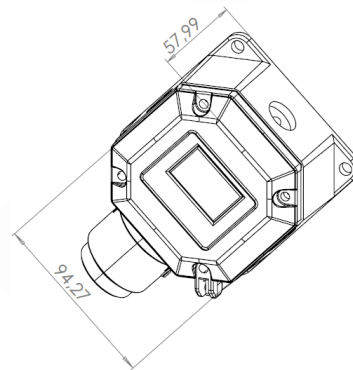
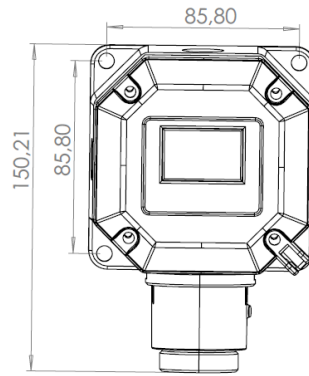

Specifications	BTN-XY44	BTN-XY42	BTN-XY41
Sensing Element	Electrochemical	Catalytic	Semi-Conductor
Output Signal	2 Alarms and 1 Fault		
Sensor Warm-up Time	60sec		
Response Time (T90)	<30*sec	<25sec	<15sec
Accuracy	%±2		
Operating Temperature	-20°C ~ +50°C		
Humidity	5 ~ 95%RH		
Input	Min 10VDC - Max 28VDC - Nominal 24VDC		
Power Consumption	Max. 3W		
Optional Outputs	Modbus RS485 RTU**		
Cable Entry	3 x PG11		
IP Rating	IP54		
Junction Box	ABS Plastic		
Sensor Head	ABS Plastic		
Dimensions/Weight	150x94,5x58mm / 250gr		
*Sensor dependent.			
**When you choose work with this option, you can get only Alarm1 and Fault relay outputs.			

XY	Gas	Product Code	Sensor Type	Measuring Range
30	LPG	BTN-3042	Catalytic	0-100%LEL
31	Methane	BTN-3142	Catalytic	0-100%LEL
33	n-Butane	BTN-3342	Catalytic	0-100%LEL
34	Propane	BTN-3442	Catalytic	0-100%LEL
36	Hydrogen	BTN-3642	Catalytic	0-100%LEL
37	Pentane	BTN-3742	Catalytic	0-100%LEL
44	Carbon monoxide	BTN-4444	Electrochemical	0-300ppm
64	Hydrogen Sulphide	BTN-6444	Electrochemical	0-100ppm
65	Oxygen	BTN-6544	Electrochemical	0-25%VOL
69	Chlorine	BTN-6944	Electrochemical	0-10ppm
72	Freon	BTN-7241	Semi-Conductor	0-2000ppm
72	Freon	BTN-7241/A*	Semi-Conductor	0-2000ppm
90	Air Quality	BTN-9041	Semi-Conductor	0-30ppm
91	A2L Class Refrigerants	BTN-9141	Semi-Conductor	0-10000ppm

*BTN-7241/A comes with 10m cable for specific applications.
Prosense gas detectors are fully tested and calibrated before delivery. Gas detectors must always be routinely controlled and calibrated regarding EN 60079-29-2.

For more information please contact with info@prosense.com.tr